

FLOWER MIU

DESIGN Cristian Feltrin



brunito corten
burnished corten



oro antico opaco
matt antique gold



pure steel
pure steel



oro chiaro
light gold

Il telaio in metallo è disponibile nelle seguenti finiture:

- brunito corten
- oro antico opaco
- pure steel
- oro chiaro

Metal frame is available in the following finishes:

- burnished corten
- matt antique gold
- pure steel
- light gold





Diffusore in vetro di Murano trasparente.

Transparent Murano glass diffuser.

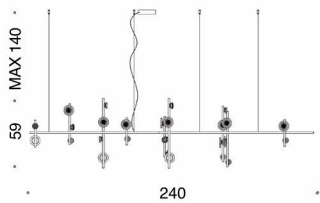
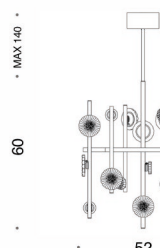

Sospensioni singole con attacco per soffitto in cartongesso - cod. 658

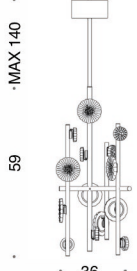
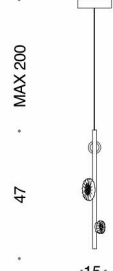
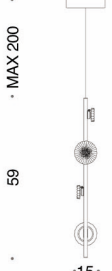
Singular suspensions with support for drywall ceiling - art. 658

SOSPENSIONE SUSPENSION

 <p>655/9SL 27 x LED 1W 3321 lumen - 3000 K</p> <p>CE ⊕ ▽</p>	 <p>655/7 17 x LED 1W 2091 lumen - 3000 K</p> <p>CE ⊕ ▽</p>	 <p>655/3+3 15 x LED 1W 1845 lumen - 3000 K</p> <p>CE ⊕ ▽</p>	
 <p>655/4 11 x LED 1W 1353 lumen - 3000 K</p> <p>CE ⊕ ▽</p>	 <p>655/1SP 3 x LED 1W 369 lumen - 3000 K</p> <p>CE ⊕ ▽</p>	 <p>655/1SM 4 x LED 1W 492 lumen - 3000 K</p> <p>CE ⊕ ▽</p>	 <p>655/1SG 5 x LED 1W 615 lumen - 3000 K</p> <p>CE ⊕ ▽</p>

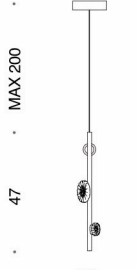

SOSPENSIONE (PER CARTONGESSO) SUSPENSION (FOR DRYWALL)

 <p>658/1SP 3 x LED 1W 369 lumen - 3000 K</p> <p>CE ⊕ ▽</p>	 <p>658/1SM 4 x LED 1W 492 lumen - 3000 K</p> <p>CE ⊕ ▽</p>	 <p>658/1SG 5 x LED 1W 615 lumen - 3000 K</p> <p>CE ⊕ ▽</p>
--	---	---

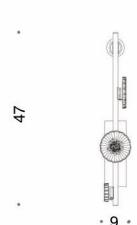

LAMPADA DA TERRA FLOOR LAMP

 <p>655/3P 15 x LED 1W 1845 lumen - 3000 K</p> <p>CE ⊕ ▽</p>
--

APPLIQUE WALL BRACKET

 <p>655/1A 4 x LED 1W 492 lumen - 3000 K</p> <p>CE ⊕ ▽</p>	 <p>655/2A 8 x LED 1W 984 lumen - 3000 K</p> <p>CE ⊕ ▽</p>
---	--

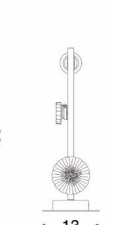
LAMPADA DA TAVOLO TABLE LAMP

 <p>655/LP 3 x LED 1W 369 lumen - 3000 K</p> <p>CE ⊕ ▽</p>	 <p>655/LG 4 x LED 1W 492 lumen - 3000 K</p> <p>CE ⊕ ▽</p>
--	--

Le finiture CORTEN (brunito) e ORO ANTICO, è un procedimento di ossidazione naturale. La realizzazione di tale processo è influenzata dal livello di umidità, dalla temperatura esterna e da altre variabili ambientali. La mano dell'uomo e la specifica lavorazione sono il valore aggiunto che testimonia l'autentico 'Made in Italy'.

Come tutte le opere dove il procedimento non è meccanico ma artigianale le eventuali variazioni di colore non sono da considerarsi un difetto ma una testimonianza dell'unicità del prodotto. Le finiture Corten e Oro antico rendono quindi il prodotto unico e irripetibile. Le foto presenti nel nostro catalogo costituiscono solo un'identificazione del tipo di prodotto e non rappresentano un campione degli stessi.

The finishes CORTEN (burnished) and ANTIQUE GOLD are the result of a procedure of natural oxidation. The procedure is every time affected by the percentage of humidity in the air, by the external temperature and by other environmental variables. Hands of man and a special processing are a value added, which is evidence of the real 'Made in Italy'.

As in all works where the procedure is not mechanical but handcrafted, variations are possible, but they must not be considered as a defect, but rather as a proof of the uniqueness of the product. The Corten and Antique gold finishes makes the product as unique, since every results is not reproducible in identical way. The pictures of our catalogues are only an example of the kind of the product, but they cannot be considered strictly as samples of them, since the result can be different.